

Dead-weight tester in compact design Model CPB3800



WIKA data sheet CT 31.06



for further approvals
see page 9

Applications

- Primary standard for calibrating the pressure scale in a hydraulic range up to 1,200 bar (16,000 psi)
- Reference instrument for factory and calibration laboratories for the testing, adjustment and calibration of pressure measuring instruments
- Complete, stand-alone system, also suitable for on-site use

Special features

- Total measurement uncertainty up to 0.025 % of reading
- Upgradeable using CPS5800/CPM5800 to provide increased accuracy to 0.006 %
- Direct replacement of original DH-Budenberg 580 series
- Factory calibration included as standard, traceable to national standards, with UKAS calibration possible as an option
- Masses manufactured from stainless steel, can be adjusted to local gravity



Dead-weight tester in compact design, model CPB3800

Description

Proven primary standard

Pressure balances (dead-weight testers) are the most accurate instruments available on the market for the calibration of electronic or mechanical pressure measuring instruments. The direct measurement of the pressure ($p = F/A$), as well as the use of high-quality materials enable a very small measurement uncertainty, in conjunction with an excellent long-term stability.

The pressure balance (dead-weight tester) has therefore been used for years in factory and calibration laboratories in industry, national institutes and research laboratories.

Stand-alone operation

Due to its integrated pressure generation and the purely mechanical measuring principle, the model CPB3800 is ideal for on-site use for maintenance and service.

Basic principle

Pressure is defined as the quotient of force and area. The core component of the CPB3800 is therefore a very precisely manufactured piston-cylinder system, onto which a mass load is applied in order to generate the individual test points.

The mass load is proportional to the target pressure and this is achieved through optimally graduated masses. As standard, these masses are manufactured to the standard gravity (9.80665 m/s^2), though they can be adjusted to a specific location and also UKAS calibrated.

Easy operation

The integrated dual-area spindle enables rapid filling of the test system and smooth pressure generation to up to 1,200 bar (16,000 psi). At the same time, the precisely adjustable spindle pump enables fine pressure adjustment. A control schematic for pressure generation on the instrument base facilitates quick and easy operation.

As soon as the measuring system reaches equilibrium, there is a balance of forces between the pressure and the masses. The excellent quality of the system ensures that this pressure remains stable over several minutes, so that the pressure value for comparative measurements can be read without any problems, or also so that more complex adjustments can be carried out on the test item.

Compact instrument version

The CPB3800 is also particularly notable for its compact dimensions, which are not altered during operation, since the spindle runs within the pump body.

With its compact dimensions, the exceptionally robust ABS plastic case and the low weight associated with these, the CPB3800 is also particularly suited to on-site applications.



Control schematic on the CPB3800 instrument base

CPB3800 with dual-range piston-cylinder systems

Next to the standard piston-cylinder systems the CPB3800 instrument base can also be combined with the CPS5800 single- or dual-range piston-cylinder systems.

With this combination the former 580 series dead-weight tester from DH-Budenberg is still available. This includes all 580L/580M/580DX and 580HX instruments and are identical in form, fit, function, specification and quality.

The table below shows WIKA's model code combinations to the corresponding 580 series models.



Dead-weight tester CPB3800 with piston unit CPS5800

Replacement instruments for DH-Budenberg 580 series

Former model designations	Replacement model code combinations				
	Instrument base	Piston-cylinder system / mass set	Range ¹⁾	Accuracy	
				Standard	Premium
580L	CPB3800	CPS5800 / CPM5800	1 ... 120 bar (10 ... 1,600 psi)	0.015 %	0.007 %
580M	CPB3800	CPS5800 / CPM5800	2 ... 300 bar (30 ... 4,000 psi)	0.015 %	0.006 %
580DX	CPB3800	CPS5800 / CPM5800	1 ... 60 bar / 10 ... 700 bar (10 ... 800 / 100 ... 10,000 psi)	0.015 %	0.006 %
580HX	CPB3800	CPS5800 / CPM5800	1 ... 60 bar / 20 ... 1,200 bar (10 ... 800 / 200 ... 16,000 psi)	0.015 %	0.007 %

1) Also available for pressure units kg/cm², psi and kPa

For detailed specifications see page 6, 8 and 9.

The standard piston-cylinder system

Both the piston and cylinder are manufactured from tungsten carbide. This pairing of materials, in comparison to other materials, has very low pressure and temperature coefficients of expansion, which results in a very good linearity for the effective area of the piston and a very high accuracy.

Piston and cylinder are very well protected against contact, impacts or contamination from outside in a solid stainless-steel case. At the same time, overpressure protection is integrated, which prevents the piston from being forced out vertically and avoids damage to the piston-cylinder system in the event of masses removal under pressure.

The masses are stacked on mass carrier, which sits on the piston shaft. The construction of the mass carrier provides a very low centre of gravity for the stacked masses, which minimises both the side thrust on the piston-cylinder system and the friction. For smaller starting pressures, the masses can also be stacked directly onto the piston shaft, without using the mass carrier.

The overall design of the piston-cylinder system and the very precise manufacturing of both the piston and the cylinder, ensures excellent operating characteristics with long free-rotation time and low sink rates. Thus a high long-term stability is ensured. Therefore, the recommended recalibration interval is two to five years dependent on the conditions of use.

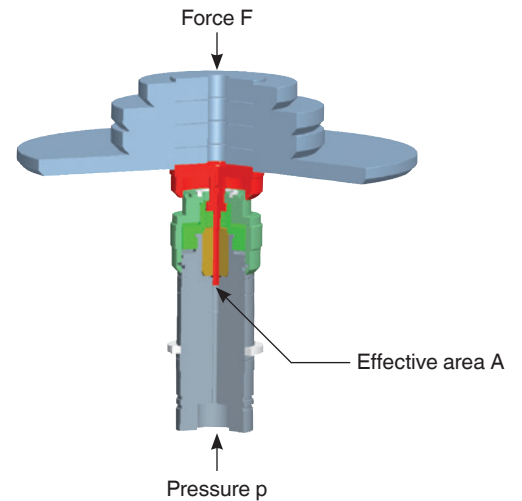

Piston-cylinder system with masses, without mass carrier

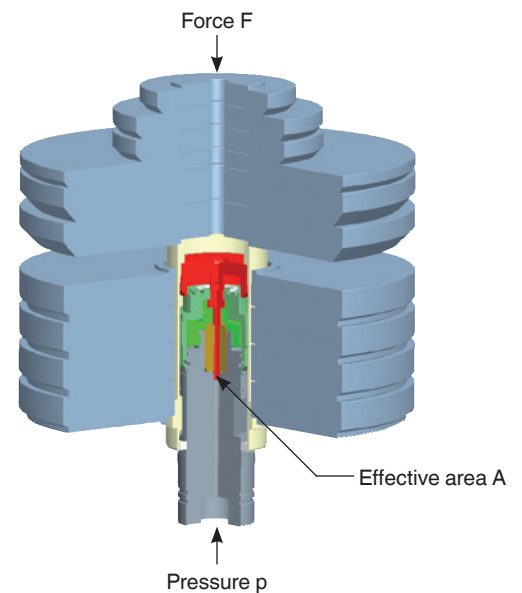

Piston-cylinder system with masses and mass carrier

The optional piston-cylinder system model CPS5800

The CPS5800 piston-cylinder systems are available in two fundamentally different designs, depending on the measuring range:

- Single-range piston-cylinder system for measuring ranges 120 bar and 300 bar (1,600 and 4,000 psi)
- Dual-range piston-cylinder system for measuring ranges 700 bar and 1,200 bar (10,000 and 16,000 psi)

High accuracy over a wide measuring range

The dual-range piston-cylinder system offers two measuring ranges in one case with automatic measuring range switching from low-pressure to high-pressure piston. This provides the user with an extremely flexible measuring instrument that can cover a wide measuring range with high accuracy, with only one piston-cylinder system and one mass set. Additionally two test points can automatically be achieved by loading the masses once.

Both the piston and cylinder are manufactured from hardened steel or tungsten carbide, respectively. This pairing of materials has very low pressure and temperature coefficients of expansion, which results in a very good linearity for the effective area of the piston and a very high accuracy.

Piston and cylinder are very well protected, against contact, impacts or contamination from outside, in a solid stainless-steel/hardened tool steel case. At the same time, overpressure protection is integrated, which prevents the piston from being forced out vertically and avoids damage to the piston-cylinder system in the event of masses removal under pressure.

The masses are stacked directly onto the piston shaft. This makes it easier for the operator to place the masses on and thus enables a lower start value.

The overall design of the piston-cylinder system and the very precise manufacturing of both the piston and the cylinder, ensure exceptionally low friction force, which results in excellent operating characteristics with long free-rotation time and low sink rates. Thus a high long-term stability is ensured. Therefore, the recommended recalibration interval is two to five years dependent on the conditions of use.

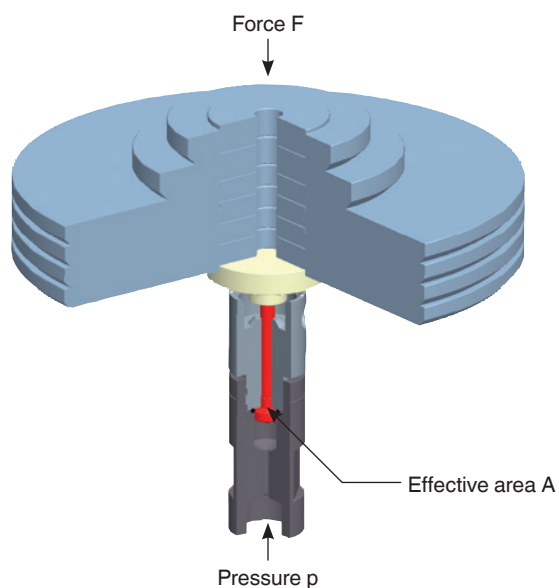

Single-range piston-cylinder system, model CPS5800

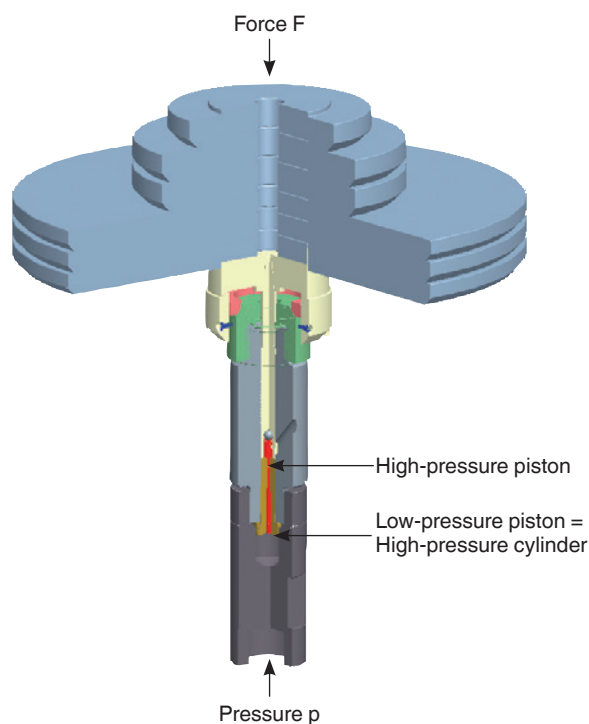

Dual-range piston-cylinder system, model CPS5800

Tables of masses

The following tables show the number of masses within a mass set with their nominal mass values and the resulting nominal pressures for the respective measuring ranges. Should the instrument not be operated under reference conditions (ambient temperature 20 °C (68 °F), atmospheric pressure 1,013 mbar (14.69 psi), relative humidity 40 %), the relevant corrections must be made, for example with the CPU6000 CalibratorUnit, see page 13.

The masses are manufactured, as standard, to the standard gravity (9.80665 m/s²) although they can be adjusted for any local gravity.

Standard mass sets

Measuring range [bar]	1 ... 120		2.5 ... 300		5 ... 700		10 ... 1,200	
	Quantity	Nominal pressure per piece [bar]	Quantity	Nominal pressure per piece [bar]	Quantity	Nominal pressure per piece [bar]	Quantity	Nominal pressure per piece [bar]
Piston and make-up weight	1	1	1	2.5	1	5	1	10
Piston, mass carrier and make-up weight for mass carrier	1	20	1	50	1	100	1	200
Masses (stackable on mass carrier)	3	20	3	50	4	100	3	200
Masses (stackable on piston)	1	20	1	50	1	100	1	200
	1	10	1	25	1	50	1	100
	2	4	2	10	2	20	2	40
	1	2	1	5	1	10	1	20
	1	1	1	2.5	1	5	1	10

Measuring range [psi]	10 ... 1,600		25 ... 4,000		50 ... 10,000		100 ... 16,000	
	Quantity	Nominal pressure per piece [psi]	Quantity	Nominal pressure per piece [psi]	Quantity	Nominal pressure per piece [psi]	Quantity	Nominal pressure per piece [psi]
Piston	1	10	1	25	1	50	1	100
Piston, mass carrier and make-up weight for mass carrier	1	190	1	475	1	950	1	1,900
Masses (stackable on mass carrier)	5	200	5	500	7	1,000	5	2,000
Masses (stackable on piston)	1	200	1	500	1	1,000	1	2,000
	1	100	1	250	1	500	1	1,000
	2	40	2	100	2	200	2	400
	1	20	1	50	1	100	1	200
	1	10	1	25	1	50	1	100

The mass sets model CPM5800 (option)

These mass sets are supplied in wooden cases with foam inserts. This includes the masses listed in the table of masses below, made from non-magnetic stainless steel, and optimised for everyday use.

For finer increments and for a higher resolution, as an option, the standard mass sets can be extended by a set of fine increment masses.

If even smaller intermediate values need to be generated, using one of the class M1 or F1 set of fine increment masses from the accessories is recommended.



Mass set model CPM5800

Measuring range [bar] or [kg/cm ²]	Single-piston measuring ranges				Dual-piston measuring ranges								
	1 ... 120		2 ... 300		1 ... 700			1 ... 1,200			1 ... 1,400		
	Quantity	Nominal pressure per piece [bar] or [kg/cm ²]	Quantity	Nominal pressure per piece [bar] or [kg/cm ²]	Quantity	Nominal pressure per piece [bar] or [kg/cm ²]	Nominal pressure per piece [bar] or [kg/cm ²]	Quantity	Nominal pressure per piece [bar] or [kg/cm ²]	Nominal pressure per piece [bar] or [kg/cm ²]	Quantity	Nominal pressure per piece [bar] or [kg/cm ²]	Nominal pressure per piece [bar] or [kg/cm ²]
Piston and make-up weight	1	1	1	2	1	1	10	1	1	20	1	1	20
Standard mass set	4	20	4	50	5	10	100	4	10	200	5	10	200
	1	18	1	45	1	9	90	1	9	180	1	9	180
	1	10	1	25	1	5	50	1	5	100	1	5	100
	2	4	2	10	2	2	20	2	2	40	2	2	40
	1	2	1	5	1	1	10	1	1	20	1	1	20
	2	1	1	3	1	0.5	5	1	0.5	10	1	0.5	10
	1	0.5	1	2.5	--	--	--	--	--	--	--	--	--
Set of fine increment masses (optional)	1	0.4	2	1	2	0.2	2	2	0.2	4	2	0.2	4
	1	0.2	1	0.5	1	0.1	1	1	0.1	2	1	0.1	2
	1	0.1	1	0.25	1	0.05	0.5	1	0.05	1	1	0.05	1
	2	0.04	2	0.1	2	0.02	0.2	2	0.02	0.4	2	0.02	0.4
	1	0.02	1	0.05	1	0.01	0.1	1	0.01	0.2	1	0.01	0.2

Specifications Model CPB3800

Piston-cylinder systems (standard)				
Measuring range ¹⁾	1 ... 120 bar	2.5 ... 300 bar	5 ... 700 bar	10 ... 1,200 bar
Required masses	41 kg	50 kg	58 kg	50 kg
Smallest step ²⁾ (Standard mass set)	1 bar	2.5 bar	5 bar	10 bar
Nominal effective area of the piston	1/16 in ²	1/40 in ²	1/80 in ²	1/160 in ²
Measuring range ¹⁾	10 ... 1,600 psi	25 ... 4,000 psi	50 ... 10,000 psi	100 ... 16,000 psi
Required masses	47 kg	47 kg	58 kg	47 kg
Smallest step ²⁾ (Standard mass set)	10 psi	25 psi	50 psi	100 psi
Nominal effective area of the piston	1/16 in ²	1/40 in ²	1/80 in ²	1/160 in ²
Accuracies				
Standard ^{3) 4)}	0.05 % of reading			
Option ^{3) 4)}	0.025 % of reading			
Pressure transmission medium	Hydraulic fluid based on VG22 mineral oil (0.5 l included in scope of delivery)			
Material				
Piston	Tungsten carbide			
Cylinder	Tungsten carbide			
Mass set	Stainless steel, non-magnetic			
Weight				
Piston-cylinder system	2.4 kg (5.3 lbs)			
bar mass set incl. mass carrier	41.5 kg (91.5 lbs)	50.5 kg (111.4 lbs)	58.5 kg (129.0 lbs)	50.5 kg (111.4 lbs)
psi mass set incl. mass carrier	47.5 kg (104.7 lbs)	47.5 kg (104.7 lbs)	58.5 kg (129.0 lbs)	47.5 kg (104.7 lbs)
Storage case for mass set (optional, 2 pieces required)	5.8 kg (12.8 lbs)			
Dimensions (W x D x H)				
Storage case for mass set (optional)	400 x 310 x 310 mm and 215 x 310 x 310 mm (15.8 x 12.2 x 12.2 in) and (8.5 x 12.2 x 12.2 in)			

- 1) Theoretical starting value; corresponds to the pressure value generated by the piston or the piston and its make-up weight (by their own weight). To optimise the operating characteristics more masses should be loaded.
- 2) The smallest pressure change value that can be achieved based on the standard mass set. To reduce this, a set of fine increment masses is also available.
- 3) The accuracy from 10 % of the measuring range is based on the measured value. In the lower range, a fixed error based on 10 % of the range applies.
- 4) Measurement uncertainty assuming reference conditions (ambient temperature 20 °C (68 °F), atmospheric pressure 1,013 mbar (14.69 psi), relative humidity 40 %). For operation without a CalibratorUnit, corrections must be made if required.

Piston-cylinder systems model CPS5800 (option)



Version	Single-piston measuring ranges		Dual-piston measuring ranges	
Measuring range ¹⁾	1 ... 120 bar	2 ... 300 bar	1 ... 60 bar / 10 ... 700 bar	1 ... 60 bar / 20 ... 1,200 bar
Required masses	49.7 kg	49.6 kg	57.4 kg	49.2 kg
Smallest step ²⁾ (Standard mass set)	0.5 bar	2.5 bar	0.5 bar / 5.0 bar	0.5 bar / 10 bar
Smallest step ³⁾ (set of fine increment masses)	0.02 bar	0.05 bar	0.01 bar / 0.1 bar	0.01 bar / 0.2 bar
Nominal effective area of the piston	0.4032 cm ²	0.1613 cm ²	0.8065 cm ² / 0.0807 cm ²	0.8065 cm ² / 0.0403 cm ²
Measuring range ¹⁾	10 ... 1,600 psi	30 ... 4,000 psi	10 ... 800 / 100 ... 10,000 psi	10 ... 800 / 200 ... 16,000 psi
Required masses	45.5 kg	45.3 kg	56.4 kg	45 kg
Smallest step ²⁾ (Standard mass set)	5 psi	20 psi	5 psi / 50 psi	5 psi / 100 psi
Smallest step ³⁾ (set of fine increment masses)	0.2 psi	0.5 psi	0.1 psi / 1 psi	0.1 psi / 2 psi
Nominal effective area of the piston	0.4032 cm ²	0.1613 cm ²	0.8065 cm ² / 0.0807 cm ²	0.8065 cm ² / 0.0403 cm ²
Measuring range ¹⁾	100 ... 12,000 kPa	200 ... 30,000 kPa	100 ... 6,000 kPa / 1,000 ... 70,000 kPa	100 ... 6,000 kPa / 2,000 ... 120,000 kPa
Required masses	49.7 kg	49.6 kg	57.4 kg	49.2 kg
Smallest step ²⁾ (Standard mass set)	50 kPa	250 kPa	50 kPa / 500 kPa	50 kPa / 1,000 kPa
Smallest step ³⁾ (set of fine increment masses)	2 kPa	5 kPa	1 kPa / 10 kPa	1 kPa / 20 kPa
Nominal effective area of the piston	0.4032 cm ²	0.1613 cm ²	0.8065 cm ² / 0.0807 cm ²	0.8065 cm ² / 0.0403 cm ²
Accuracies				
Standard ^{4) 5)}	0.015 % of reading			
Premium ^{4) 5)}	0.007 % of reading	0.006 % of reading	0.007 % of reading	
Pressure transmission medium				
Standard	Hydraulic fluid based on VG22 mineral oil ⁶⁾			
Material				
Piston	Steel	Steel	Steel / tungsten carbide	Steel / tungsten carbide
Cylinder	Bronze	Steel	Steel / tungsten carbide	Steel / tungsten carbide
Mass set	Stainless steel, non-magnetic			
Weight				
Piston-cylinder system	1 kg (2.2 lbs)	0.8 kg (1.8 lbs)	2 kg (4.4 lbs)	2 kg (4.4 lbs)
Storage case for the piston-cylinder system	3.1 kg (6.8 lbs)			
bar standard mass sets (in 2 wooden cases)	61.3 kg (135.2 lbs)	61.2 kg (134.9 lbs)	69 kg (152.1 lbs)	60.8 kg (134.1 lbs)
psi standard mass sets (in 2 wooden cases)	57.1 kg (125.9 lbs)	56.9 kg (125.5 lbs)	68 kg (149.9 lbs)	56.6 kg (124.8 lbs)
bar set of fine increment masses	0.33 kg (0.73 lbs)	0.5 kg (1.1 lbs)	0.5 kg (1.1 lbs)	0.5 kg (1.1 lbs)
psi set of fine increment masses	0.23 kg (0.5 lbs)	0.34 kg (0.75 lbs)	0.34 kg (0.75 lbs)	0.34 kg (0.75 lbs)
Dimensions (W x D x H)				
Carrying case for standard mass sets	400 x 310 x 310 mm (15.8 x 12.2 x 12.2 in)			
Storage case for the piston-cylinder system (optional)	300 x 265 x 205 mm (11.8 x 10.4 x 8.1 in)			

- Theoretical starting value; corresponds to the pressure value generated by the piston or the piston and its make-up weight (by their own weight). To optimise the operating characteristics more masses should be loaded.
- The smallest pressure change value that can be achieved based on the standard mass set. To reduce this, a set of fine increment masses is also available.
- The smallest pressure change value that can be achieved based on the optional set of fine increment masses. For further reductions, an accessory of class M1 or F1 set of fine increment masses is available.
- The accuracy from 10 % of the measuring range is based on the measured value. In the lower range, the accuracy is 0.03 % of reading for the single-range piston-cylinder systems and 0.025 % of reading for dual-range piston-cylinder systems.
- Measurement uncertainty assuming reference conditions (ambient temperature 20 °C (68 °F), atmospheric pressure 1,013 mbar (14.69 psi), relative humidity 40 %). For operation without a CalibratorUnit, corrections must be made if required.
- Other pressure transmission media on request.

Base	
Connections	
Connection for piston-cylinder system	G ¾ B (male)
Test item connection	G ½ female thread, loose union connection
Material	
Wetted parts	Austenitic stainless steel, high-tensile brass, nitrile rubber
Pressure transmission medium	
Reservoir	Hydraulic fluid based on VG22 mineral oil (0.5 l included in scope of delivery) ⁶⁾ 170 cm ³
Weight	
Base	13.5 kg (29.8 lbs)
Storage case for the base (optional)	8.5 kg (18.7 lbs)
Permissible ambient conditions	
Operating temperature	18 ... 28 °C (64 ... 82 °F)
Dimensions (W x D x H)	
Base	401 x 397 x 155 mm (15.8 x 15.7 x 6.1 in), for details, see technical drawings

6) Other pressure transmission media on request.

Approvals

Logo	Description	Country
	EC declaration of conformity Pressure equipment directive (Module A)	European Community
	GOST Metrology/measurement technology	Russia
-	MTSCHS Permission for commissioning	Kazakhstan

Certificates

Certificate	
Calibration	Calibration certificate Option: UKAS calibration certificate (pressure calibration with a mass set) for CPB3800 standard models Option: UKAS calibration certificate (area and mass calibration) for CPS/CPM5800 only
Recommended recalibration interval	2 to 3 years (dependent on conditions of use)

Approvals and certificates, see website

Transport dimensions for complete instrument

The complete instrument, in its standard version and standard scope of delivery, consists of three packages on a single pallet. The dimensions are 1,200 x 800 x 500 mm (47.2 x 31.5 x 19.7 in). The overall weight is dependent on the measuring range.

Standard units CPB3800

Version	Weight	
	net	gross
1 ... 120 bar	71 kg (156.6 lbs)	89 kg (196.2 lbs)
2.5 ... 300 bar	71 kg (156.6 lbs)	89 kg (196.2 lbs)
5 ... 700 bar	71 kg (156.6 lbs)	89 kg (196.2 lbs)
10 ... 1,200 bar	71 kg (156.6 lbs)	89 kg (196.2 lbs)

Version	Weight	
	net	gross
10 ... 1,600 psi	68 kg (149.9 lbs)	86 kg (189.6 lbs)
25 ... 4,000 psi	68 kg (149.9 lbs)	86 kg (189.6 lbs)
50 ... 10,000 psi	68 kg (149.9 lbs)	86 kg (189.6 lbs)
100 ... 16,000 psi	68 kg (149.9 lbs)	86 kg (189.6 lbs)

Optional CPS/CPM5800 units with CPB3800 base

Version	Weight	
	net	gross
Single-piston measuring ranges		
1 ... 120 bar	77 kg (169.8 lbs)	95.5 kg (210.6 lbs)
2 ... 300 bar	77 kg (169.8 lbs)	95.5 kg (210.6 lbs)
Dual-piston measuring ranges		
1 ... 60 bar / 10 ... 700 bar	85.5 kg (188.5 lbs)	104 kg (229.3 lbs)
1 ... 60 bar / 20 ... 1,200 bar	77.5 kg (170.9 lbs)	96 kg (211.7 lbs)
1 ... 60 bar / 20 ... 1,400 bar	85.5 kg (188.5 lbs)	104 kg (229.3 lbs)

Version	Weight	
	net	gross
Single-piston measuring ranges		
10 ... 1,600 psi	73 kg (161 lbs)	91.5 kg (201.8 lbs)
30 ... 4,000 psi	72.5 kg (159.9 lbs)	91 kg (200.7 lbs)
Dual-piston measuring ranges		
10 ... 800 psi / 100 ... 10,000 psi	84.5 kg (186.3 lbs)	103 kg (227.1 lbs)
10 ... 800 psi / 200 ... 16,000 psi	73 kg (161 lbs)	91.5 kg (201.8 lbs)
10 ... 800 psi / 200 ... 20,000 psi	84.5 kg (186.3 lbs)	103 kg (227.1 lbs)

Dimensions in mm (in)

(without masses)

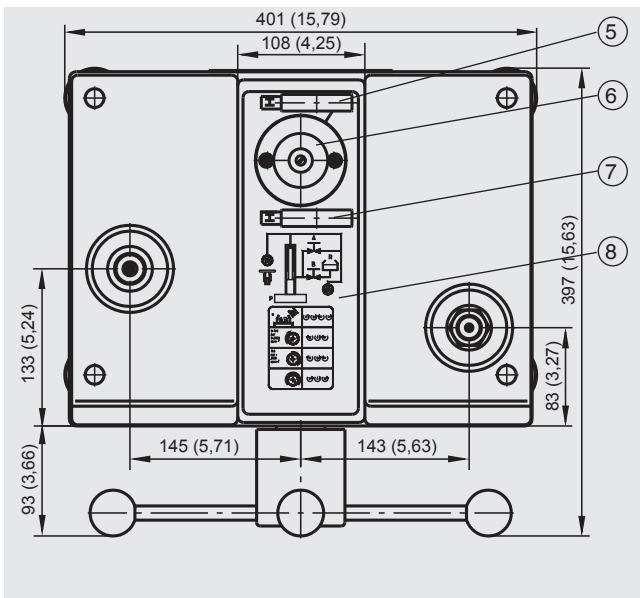
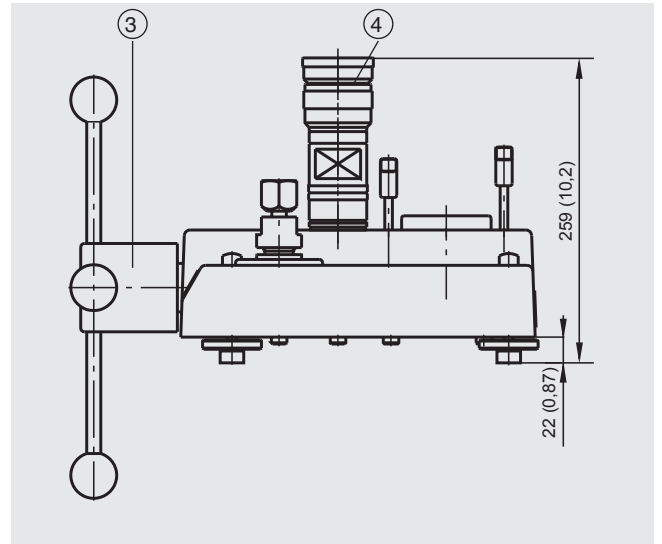
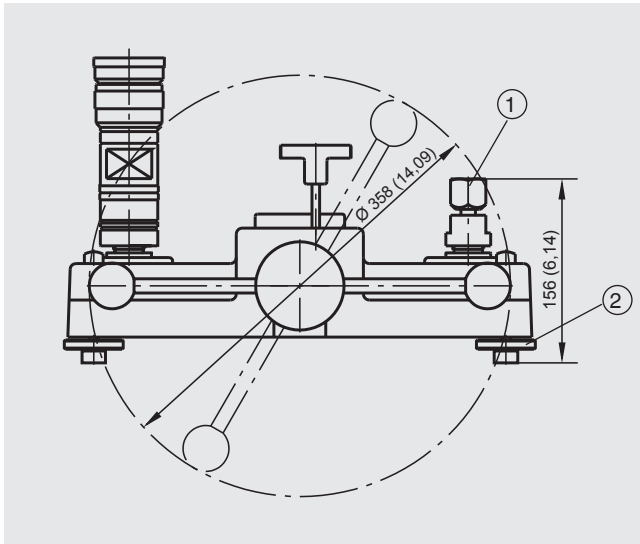

- ① Test connection
- ② Rotatable feet
- ③ Dual-area pump with star handle
- ④ Piston-cylinder system
- ⑤ High-pressure shut-off valve
- ⑥ Reservoir with plug screw
- ⑦ Low-pressure shut-off valve
- ⑧ Pressure generation control schematic

Standard connection piston-cylinder system

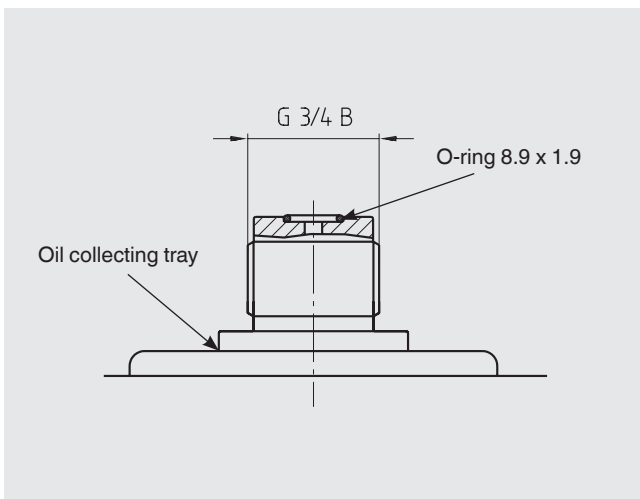

Test connection

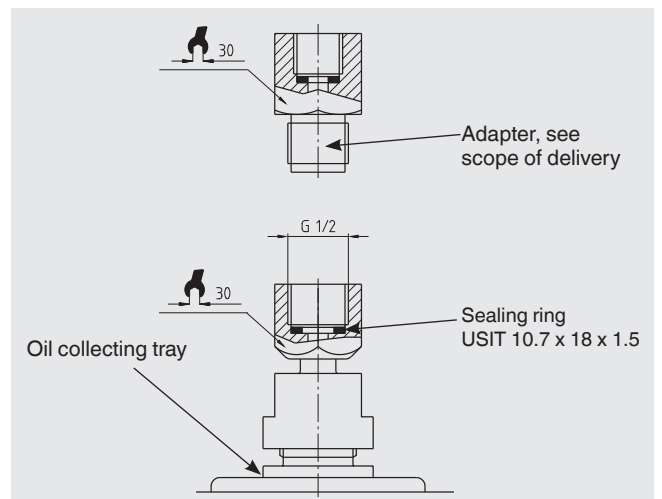

CalibratorUnit model CPU6000

The models of the CPU6000 series are compact tools for use with a pressure balance (dead-weight tester). In particular when highly accurate measuring values, with measurement uncertainties of less than 0.025 %, are required, complicated mathematical calculations and corrections are necessary. With the CPU6000 in combination with the CPB-CAL (iPad® app) and/or WIKA-CAL (PC software) all critical ambient parameters can be registered and automatically corrected.

The CPU6000 series is made up of three instruments

Weather station, model CPU6000-W

The CPU6000-W provides measured values such as atmospheric pressure, relative humidity and the ambient temperature of the laboratory environment.

Pressure balance sensor box, model CPU6000-S

The CPU6000-S measures the piston temperature and displays the floating position of the masses.

Digital multimeter, model CPU6000-M

The CPU6000-M fulfils the function of a digital multimeter and power supply unit when electronic pressure transmitters must be calibrated.

Typical application

CPB-CAL iPad® app

The iPad® application calculates the masses for pressure balances (dead-weight testers) or the reference pressure while taking the measured parameters from the CPU6000 into account. The conversion can be carried out in all common pressure units. As an additional parameter, the local gravity can be given for location-independent measurements.

WIKA-CAL PC software - Weight calculator

With the demo version of the WIKA-CAL software and a CPB series pressure balance (dead-weight tester), the masses to be applied and the corresponding reference pressure can be determined. The pressure balance data (dead-weight tester data) can be entered into the database manually or imported automatically via an XML file available online. All ambient parameters and piston temperature can be entered manually into WIKA-CAL or can be measured automatically with the CPU6000 series, so that the highest accuracy can be achieved. WIKA-CAL demo version can be downloaded free of charge from the WIKA website.

Further specifications on the CPU6000 series can be found in data sheet CT 35.02.

For details of the WIKA-CAL calibration software see data sheet CT 95.10.



CPU6000 series and iPad® app CPB-CAL



Model CPU6000-W, CPU6000-S, CPB5800 and PC with WIKA-CAL software

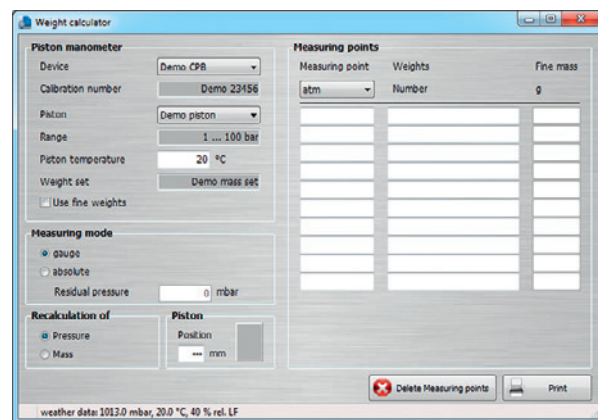

WIKA-CAL PC software - Weight calculator

Further pressure balances / dead-weight testers within our calibration technology programme

Hydraulic pressure balance, model CPB5800

Measuring ranges:

Hydraulic Single-piston measuring ranges:
 1 ... 120 to 2 ... 300 bar
 (10 ... 1,600 to 30 ... 4,000 psi)

 Dual-piston measuring ranges:
 1 ... 60 bar / 10 ... 700 bar to
 1 ... 60 bar / 20 ... 1,400 bar
 (10 ... 800 psi / 100 ... 10,000 psi to
 10 ... 800 psi / 200 ... 20,000 psi)

Accuracy: 0.015 % of reading
 up to 0.006 % of reading (optional)

For specifications see data sheet CT 31.11



Hydraulic pressure balance, model CPB5800

Pneumatic pressure balance, model CPB5000

Measuring ranges:

Pneumatic -0.03 ... -1 to +0.4 ... +100 bar
 (-0.435 ... -14 to +5.8 ... +1,500 psi)

Accuracy: 0.015 % of reading
 0.008 % of reading (optional)

For specifications see data sheet CT 31.01



Pneumatic pressure balance, model CPB5000

Pressure balance for high pressure, model CPB5000HP

Measuring ranges:

Hydraulic 25 ... 2,500, 25 ... 4,000 or 25 ... 5,000 bar
 (350 ... 40,000, 350 ... 60,000 or
 350 ... 70,000 psi)

Accuracy: 0.025 % of reading
 0.02 % of reading (optional)

For specifications see data sheet CT 31.51



Pressure balance for high pressure, model CPB5000HP

Pressure balance for differential pressure, model CPB5600DP

Measuring ranges (= static pressure + differential pressure):

Pneumatic 0.03 ... 2 to 0.4 ... 100 bar
 (0.435 ... 30 to 5.8 ... 1,500 psi)

Hydraulic 0.2 ... 60 to 25 ... 1,600 bar
 (2.9 ... 1,000 to 350 ... 23,200 psi)

Accuracy: 0.015 % of reading
 0.008 % of reading (optional)

For specifications see data sheet CT 31.56



Pressure balance for differential pressure, model CPB5600DP

Accessories

Set of fine increment masses M1 and F1

The masses included in the standard mass set are ideally suited for everyday use. If even smaller intermediate values need to be generated, using one of the class M1 or F1 set of fine increment masses with the following masses is recommended:

1 x 50 g, 2 x 20 g, 1 x 10 g, 1 x 5 g, 2 x 2 g, 1 x 1 g,
1 x 500 mg, 2 x 200 mg, 1 x 100 mg, 1 x 50 mg, 2 x 20 mg,
1 x 10 mg, 1 x 5 mg, 2 x 2 mg, 1 x 1 mg



Set of fine increment masses

Test connections

With the existing standard test item connection, test items with radial connection points can be mounted. For units with rear connection points, a 90° angled connection piece is available.

With a G 3/4 female to G 1/2 female connector, loose union connection, which can be mounted in place of the piston-cylinder system on the piston connection, the CPB3800 instrument base can be used as a comparison test pump.



Fig. left: Gauge adapter, G 3/4 female to G 1/2 female
Fig. right: 90° angle connector

Separators

The separators (with diaphragm) have been specifically designed for measuring instruments, which should not come into contact with the medium of the pressure balance (dead-weight tester) or to protect the pressure balance (dead-weight tester) against contamination from the test items.



Fig. left: Separator (with diaphragm) 700 bar (10,000 psi)
Fig. right: Separator (with diaphragm) 1,200 bar (16,000 psi)

Designation/Version	Order no.
Set of fine increment masses (1 mg up to 50 g), class F1	7093874
Set of fine increment masses (1 mg up to 50 g), class M1	14025325
Set of 2 carrying cases for bar mass set	14031236
Set of 2 carrying cases for psi mass set	14068416
Carrying case for CPB3800 instrument base	14031237
Adapter set "BSP" for G 1/2 B male test item connector to G 1/8, G 1/4, G 3/8 and G 1/2 female	14031238
Adapter set "NPT" for test item connection G 1/2 B male on 1/8 NPT, 1/4 NPT, 3/8 NPT and 1/2 NPT female	14031239
Adapter set "metric" for test item connection G 1/2 B male on M12 x 1.5 and M20 x 1.5 female	14031242
Test item connection, G 3/4 female to G 1/2 female, rotating	14031251
Angled connection piece 90°, for test items with back mounting connection	1564838
Separator (to separate two liquid media by a diaphragm), max. 700 bar (10,000 psi)	14031253
Separator (to separate two liquid media by a diaphragm), max. 1,200 bar (16,000 psi)	14031254
Sealing set for CPB3800 instrument base	14031255
Operating fluid for CPB series up to max. 4,000 bar (60,000 psi), 0,5 litre	2099954
Tool set consisting of open-ended spanner, BSP adapter, replacement seals, pointer remover and pointer punch	14031263

Scope of delivery

- Base
- Dual-area spindle pump for filling, pressure generation and fine pressure adjustment
- Piston connection with G 3/4 B male thread
- Test item connection with G 1/2 female thread, loose union connection
- Adapter set for test item selectable from 3 different sets:
 - Adapter set "BSP" G 1/2 male on G 1/8, G 1/4, G 3/8 and G 1/2 female
 - Adapter set "NPT" G 1/2 male on 1/8 NPT, 1/4 NPT, 3/8 NPT and 1/2 NPT female
 - Adapter set "metric" G 1/2 male on M12 x 1.5 and M20 x 1.5 female
- Piston-cylinder system
- Masses manufactured to local gravity (standard value: 9.80665 m/s²)
- VG22 mineral oil (0.5 litre)
- Tool and maintenance set
- Operating instructions in German and English language
- Factory calibration certificate

Options

- Systems with increased accuracy to 0.006 %
- Further pressure transmission media
- Further pressure units
- Set of fine increment masses (CPS/CPM5800 option only)
- Masses, manufactured to local gravity
- Storage case for the base, mass set (included as standard for CPS5800/CPM5800 options) and the piston-cylinder system
- UKAS calibration certificate

Ordering information

Instrument base

CPB3800 / Instrument version / Accuracy / Gravity value g / Standard adapter set / Storage case / Calibration for pressure balance / Additional ordering information

Piston-cylinder system

CPS5800 / Accuracy / Gravity value g / Measuring range / Connection of piston-cylinder system / Storage case for piston-cylinder system / Calibration for piston-cylinder system / Additional ordering information

Mass set

CPM5800 / Pressure unit / Gravity value g / Standard mass set / Set of fine increment masses / Calibration for standard mass set / Calibration for set of fine increment masses / Additional ordering information

© 2012 WIKA Alexander Wiegand SE & Co. KG, all rights reserved.
The specifications given in this document represent the state of engineering at the time of publishing.
We reserve the right to make modifications to the specifications and materials.

