

Pressure balance

High-pressure version

Model CPB5000HP



WIKA data sheet CT 31.51

Applications

- Primary standard for defining the pressure scale in a range up to 5,000 bar
- Reference instrument for testing, adjusting and calibrating pressure measuring instruments in factories and calibration laboratories
- Self-contained, complete system also suitable for on-site measurements/calibrations

Special features

- Total uncertainty of measurement down to 0.02 % of reading
- Factory calibration certificate as standard, traceable to National Standards, DKD/DAkks calibration certificate available as an option
- High long-term stability with a recommended recalibration cycle of 5 years
- Masses manufactured from stainless steel and aluminium, local gravity adjustment possible at no additional charge



High-pressure pressure balance model CPB5000HP

Description

Proven primary standard

Pressure balances are the most accurate instruments for the calibration of electronic or mechanical pressure measuring instruments. The direct measurement of pressure, ($P = F/A$) and the use of high-quality materials, result in small measurement uncertainties and an excellent long-term stability of five years (Recommendation in accordance with the German Calibration Service DKD/DAkks).

For these reasons pressure balances have already been used in the calibration laboratories of industry, national institutes and research laboratories for many years.

Self-contained operation

Due to the integrated pressure generation and the purely mechanical measuring principle, the CPB5000 is ideally suited to on-site use as well as service and maintenance purposes.

Basic principle

Pressure is defined as the quotient of force and area. Correspondingly, the core of the CPB5000 is a very precisely-manufactured piston cylinder system, which is loaded with masses in order to generate the individual test points.

The weight applied is proportional to the desired pressure and accomplished by using optimally graduated weights. These weights are manufactured to standard gravity (9.80665 m/s^2) although, for fixed location usage, they can be adjusted to a customer-specified local gravity.

Easy operation

The pressure is set via an integrated pump. For fine adjustment a very precisely adjustable spindle pump with a precision spindle running only within the pump body is mounted. As soon as the measuring system reaches equilibrium, there is a balance of forces between pressure and mass applied. The excellent quality of the system ensures that this pressure remains stable over several minutes, so that the device under test can be calibrated or time-consuming adjustments can be carried out without any problems.

Solid instrument design

With the highpressure model calibrations up to a maximum pressure of 5,000 bar are possible. It has been designed around a solid platform and offers exceptional ease-of-use. With the integrated initial pressure pump and the 250 ml tank, large test volumes can also be easily filled and pre-compressed.

The piston cylinder system is fixed to the basement and has special bearings ensuring excellent operating characteristics with a long free rotation time and low fall rates and a very high long-term stability also at high pressures and forces. Therefore the recommended recalibration interval is 5 years.

The materials of the piston and cylinder have very small pressure and thermal expansion coefficients, which results in a very good linearity of the effective cross-sectional area of the piston and high measurement accuracy.

The test connection is equipped with a knurled nut and interchangeable threaded adapters with metal sealing cones. M16 x 1.5, M20 x 1.5 and 9/16-18 UNF adapters are in scope of supply.

Tables of masses

The following tables show the number of weights per measuring range, within a weight set, with their nominal mass values and the resulting nominal pressures. Should you not operate the device under reference conditions (ambient temperature 20 °C, air pressure 1013 mbar, relative humidity 40 %), corrections must be considered, if necessary.

These weights are manufactured to standard gravity (9.80665 m/s²) although, for fixed location usage, they can be adjusted to a customer-specified local gravity.

Measuring range [bar]	25 ... 2,500		25 ... 4,000		25 ... 5,000	
	Pieces	Nominal pressure per piece	Pieces	Nominal pressure per piece	Pieces	Nominal pressure per piece
Piston incl. bell jar	1	25	1	25	1	25
Masses 5 kg	-	-	6	250	10	250
Masses 4 kg	8	200	8	200	8	200
Masses 2 kg	9	100	9	100	9	100
Masses 1 kg	1	50	1	50	1	50
Masses 0.5 kg	2	25	2	25	2	25
Masses 0.2 kg	1	10	1	10	1	10
Masses 0.1 kg	1	5	1	5	1	5
Masses 0.05 kg	1	2.5	1	2.5	1	2.5

Measuring range [psi]	350 ... 40,000		350 ... 60,000		350 ... 70,000	
	Pieces	Nominal pressure per piece	Pieces	Nominal pressure per piece	Pieces	Nominal pressure per piece
Piston incl. bell jar	1	350	1	350	1	350
Masses 7 kg	2	5,000	6	5,000	8	5,000
Masses 3.5 kg	8	2,500	8	2,500	8	2,500
Masses 1.4 kg	8	1,000	8	1,000	8	1,000
Masses 1 kg	1	750	1	750	1	750
Masses 0.7 kg	2	500	2	500	2	500
Masses 0.35 kg	1	250	1	250	1	250
Masses 0.14 kg	1	100	1	100	1	100
Masses 0.07 kg	1	50	1	50	1	50

Specifications

Model CPB5000HP

Measuring range	bar ¹⁾	25 ... 2,500	25 ... 4,000	25 ... 5,000
Required weights	kg	50	80	100
Smallest step	bar ²⁾	2.5	2.5	2.5
Nominal cross-sectional area of the piston	cm ²	0.02	0.02	0.02
Measuring range	psi ¹⁾	350 ... 40,000	350 ... 60,000	350 ... 70,000
Required weights	kg	55	83	97
Smallest step	psi ²⁾	50	50	50
Nominal cross-sectional area of the piston	cm ²	0.02	0.02	0.02
Accuracy ³⁾	% of reading	0.025 / optional: 0.02 ⁴⁾		
Pressure transmission medium		up to 4,000 bar/60,000 psi: mineral oil based hydraulic fluid (1 litre is included in delivery) 5,000 bar/70,000 psi: Sebacate-oil (0.5 litre is included in delivery)		
Oil reservoir	cm ³	250		
Connection for the test specimen		test specimen can be freely positioned, 3 threaded adapters as standard M16 x 1.5 / M20 x 1.5 and 9/16-18UNF for other threaded adapters, see accessories		
Material				
■ Piston		hardened steel		
■ Cylinder		tungsten carbide		
■ Mass-set		stainless steel 1.4305 and aluminium, non-magnetic		
■ Piping in instrument base		stainless steel 1.4404, 6 x 2 mm		
Operating temperature	°C	18 ... 28		
Weight				
■ Instrument base, high pressure	kg	32.5		
■ Piston cylinder system	kg	2.7 / 5.0 (incl. storage suit case)		
■ BAR basic mass-set, part 1	kg	34.0 (incl. carrying case)		
■ BAR basic mass-set, part 2	kg	27.5 (incl. carrying case)		
■ BAR mass-set extension, part 1 (for 4,000 bar and 5,000 bar)	kg	33.5 (incl. carrying case)		
■ BAR mass-set extension, part 2 (only for 5,000 bar)	kg	23.5 (incl. carrying case)		
Weight				
■ PSI basic mass-set, part 1	kg	51.0 (incl. carrying case)		
■ PSI basic mass-set, part 2	kg	15.0 (incl. carrying case)		
■ PSI mass-set extension, part 1 (for 60,000 psi and 70,000 psi)	kg	31.8 (incl. carrying case)		
■ PSI mass-set extension, part 2 (only for 70,000 psi)	kg	17.8 (incl. carrying case)		
Dimensions				
■ Instrument base	mm	460 (W) x 445 (D) x 265 (H), for details see technical drawing		
■ Carrying case for basic mass-set, part 1	mm	400 (W) x 310 (D) x 310 (H)		
■ Carrying case for basic mass-set, part 2	mm	215 (W) x 310 (D) x 310 (H)		
■ Carrying case for mass-set extension	mm	215 (W) x 310 (D) x 310 (H)		
■ Carrying case for piston cylinder system	mm	370 (W) x 150 (D) x 150 (H)		
CE-conformity				
■ Pressure equipment directive		97/23/EG (Module A)		
Calibration		Factory calibration certificate (optional: DKD/DAkkS calibration certificate)		

1) Theoretical starting value; corresponds to the pressure value generated by the piston (by its own weight). To optimise the operating characteristics more weights should be loaded.

2) The lowest pressure change value that is reached based on the standard weight set. A fine weight set is also available for lower values.

3) The accuracy is in reference to the measurement value, from 10 % of the measurement range. A fixed error is considered in the lower area in reference to 10 % of the area.

4) Measurement uncertainty assuming reference conditions (room temperature 20 °C, air pressure 1013 mbar, relative humidity 40 %). Corrections may be required for use without CalibratorUnit.

Dimensions in mm

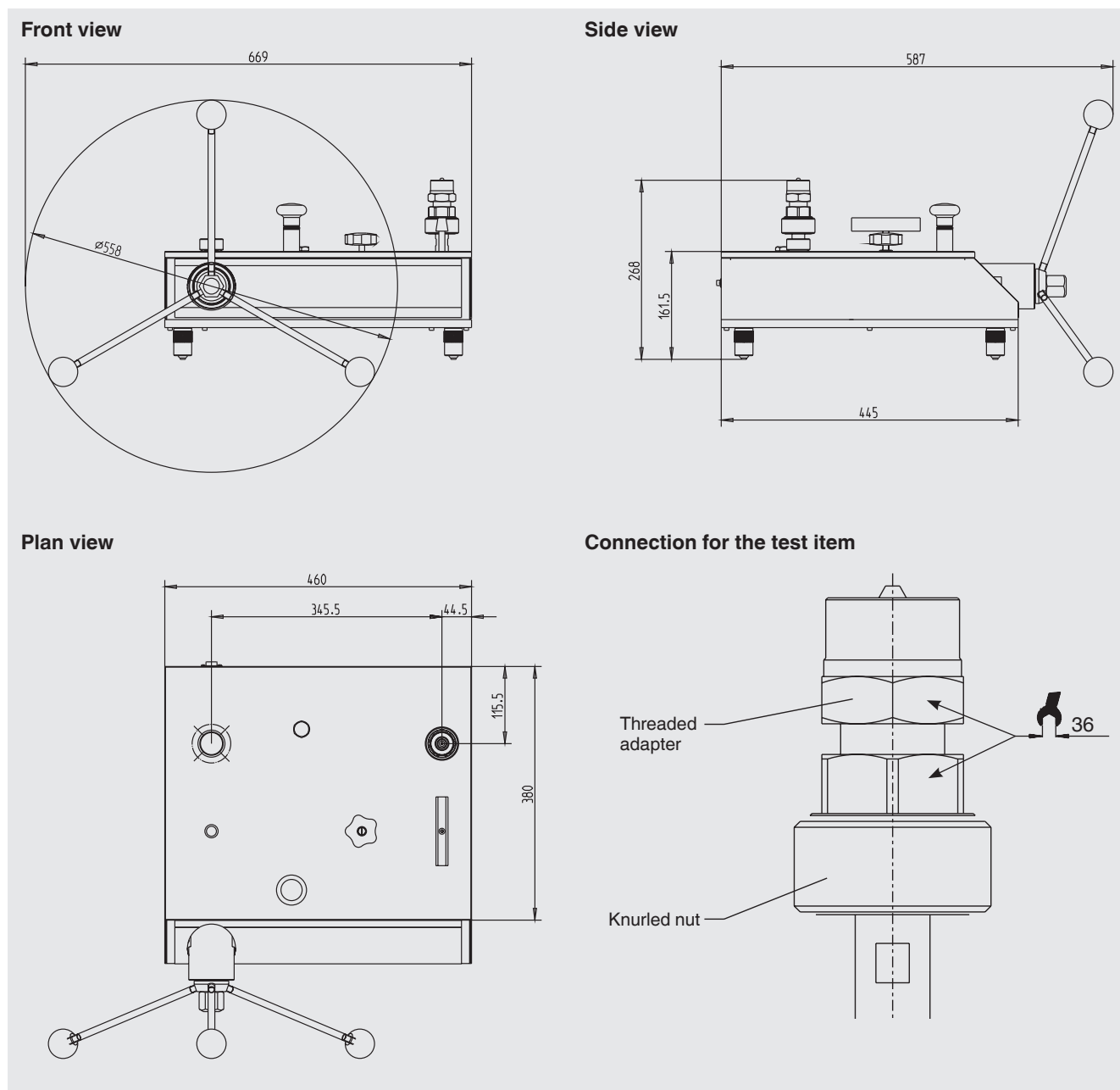

Scope of supply

- Instrument base with dust cover
- Initial pressure pump
- Spindle pump for pressure generation/fine adjustment
- Connection for piston cylinder system
- Connection for test devices with 3 threaded adapters M16 x 1.5 / M20 x 1.5 and 9/16-18 UNF
- Piston cylinder system with bell jar
- Basic mass set divided into 2 carrying cases
- Mass-set extension in 1 carrying case (for 4,000 bar or 60,000 psi resp. in 2 carrying cases for 5,000 bar or 70,000 psi)
- Mass-set manufactured to standard gravity (9.80665 m/s²)
- Operating fluid 1.0 litre (up to 4,000 bar/60,000 psi)
- Operating fluid 0.5 litre (for 5,000 bar/70,000psi)

- Wrenches 36 flats and 46 flats
- Operating instructions in German and English
- Factory calibration certificate

Options

- Systems with increased accuracy to 0.02 %
- Mass-set manufactured to local gravity
- DKD/DAkkS calibration certificate

CalibratorUnit model CPU5000

The CPU5000 CalibratorUnit is a compact tool for use with a pressure balance. Particularly when highly-accurate measuring values, with uncertainties of measurement of less than 0.025 %, are required, complicated mathematic calculations and corrections are necessary. With the CPU5000 all critical ambient parameters can be registered and automatically corrected.

Basis package CPU5000

The basic CalibratorUnit package converts masses into the corresponding pressure value, or vice versa, it calculates the masses required for a specific pressure value by considering the local gravity on-site. The conversion can be carried out in all common pressure units. The input of all parameters takes place manually.

Sensor package

The sensor package extension includes sensors to automatically register all critical parameters like room temperature, air pressure, relative humidity and piston temperature and a continual updating of the calculations possible.

Multimeter package

Furthermore with the multimeter package, a calibrator function for pressure transmitters can be integrated, so that a voltage of DC 24 V can be supplied to the test item sensors and sensor signals (V, mA) can be measured without any additional devices. Besides the signal the automatically converted pressure value is also shown on the display.

Piston position display

By upgrading the CPU5000 with the extension for float position indication, the piston position can be measured contact-free and shown on the CalibratorUnit with high resolution.

Further specifications to CalibratorUnit CPU5000 see data sheet CT 35.01.



CalibratorUnit model CPU5000

Order variants

CPU5000 Basis package (only processor)

- Calculation of the mass-loads
- Manual input of all parameters

Sensor package for measuring of:

- Ambient temperature
- Air pressure
- Air humidity
- Piston temperature

Multimeter package

- Power supply DC 24 V
- Measuring of output signal (V, mA) incl. conversion into pressure values

Piston position display

- Contact-free measuring of piston position

Accessories

Set of trim-masses

The weights included in the standard scope of delivery are ideally suited for everyday use. If you would like to generate intermediate values, however, we recommend using a set of class F1 trim-masses, with the following weights:

1 x 50 g / 2 x 20 g / 1 x 10 g / 1 x 5 g / 2 x 2 g / 1 x 1 g /
 1 x 500 mg / 2 x 200 mg / 1 x 100 mg / 1 x 50 mg /
 2 x 20 mg / 1 x 10 mg / 1 x 5 mg / 2 x 2 mg / 1 x 1 mg



Set of trim-masses

Description / Features	Order no.
Trim-masses (1 mg up to 50 g), class F1	7093874
Adapter for test item connection with G ½ female thread, max. 1,600 bar, material stainless steel 1.4571	11095912
Operating fluid for CPB5000 up to 4,000 bar, 1 litre	2099882
Operating fluid for CPB5000 up to 5,000 bar, 0.5 litre	11123150

Further pressure balances within our calibration technology programme

Pressure balance model CPB3000

Measuring ranges:

- hydraulic: 60 bar up to 1,000 bar resp.
1,000 psi up to 14,500 psi

Accuracy: 0.025 % of reading

Specifications according to data sheet CT 31.05



Pressure balance model CPB3000

Pressure balance model CPB5000

Measuring ranges:

- pneumatic: -1 bar up to 100 bar resp.
-14 psi up to 1,500 psi
- hydraulic: 60 bar up to 1,000 bar resp.
1,000 psi up to 14,500 psi

Accuracy: 0.015 % of reading
0.008 % of reading (optional)

Specifications according to data sheet 31.01



Pressure balance model CPB5000

Differential pressure balance model CPB5000DP

Measuring ranges

(= static line pressure + differential pressure):

- pneumatic: 2 bar up to 100 bar resp.
30 psi up to 1,500 psi
- hydraulic: 60 bar up to 1,000 bar bzw.
1,000 psi up to 14,500 psi

Accuracy: 0.015 % of reading
0.008 % of reading (optional)

Specifications according to data sheet CT 31.52



Differential pressure balance model CPB5000DP

Products and services within our calibration technology programme

- DKD/DAkkS calibration services for pressure
- Repair of calibration units of all makes
- Portable pressure measuring devices for test and calibration tasks
- Precision pressure measuring units and pressure controllers
- Primary standards for pressure
- Testing technology system solutions
- DKD/DAkkS calibration services for temperature
- Portable measuring devices and calibrators
- Dry well temperature calibrators
- Calibration baths and furnaces
- Precision thermometers
- Primary standards for temperature
- Consulting and seminars

The specifications given in this document represent the state of engineering at the time of publishing. We reserve the right to make modifications to the specifications and materials.

